



DELIVERING MORE

**7,000 – 11,000 LB. CAPACITY
ELECTRIC PNEUMATIC TIRE LIFT TRUCKS**



MORE

Moving Your Business Forward

The 2EPC7000-2EP11000 series from Cat[®] Lift Trucks is built to perform. Delivering all of the benefits you'd expect from an IC truck – rugged performance, powerful acceleration and industry-leading lift speeds – with the energy efficiency that only comes from an electric.

What does this mean for your operation?

Increased efficiency, zero emissions and a drastically lower per-shift operating cost – today and over the long haul.



CAT[®] POWER

ADVANTAGES TO YOU:

- **Lower total cost of ownership** – On average, the overall lifecycle operating costs for electric forklifts are one quarter of the cost compared to IC lift trucks*, resulting in a lower cost of ownership without sacrificing performance.
- **Versatility** – Offering lift truck capacities up to 11,000 lbs., this series is flexible for use in both indoor and outdoor applications. Sealed components provide added protection from dust, debris and moisture, resulting in a lift truck that is built to operate in even the most demanding environments.
- **Longer run times** – Innovative AC technology, combined with intelligent design and close proximity of components, enables this lift truck to operate up to two shifts on one battery charge¹⁾. Reduced maintenance needs keep your lift trucks in operation longer, resulting in a better bottom line.
- **Zero fuel costs, zero emissions** – A cleaner running truck means a cleaner working environment. And, with no fuel costs, your business will save more annually in addition to benefiting from zero exhaust emissions.

THE ELECTRIC BENEFIT

See how an electric lift truck can save you more over the long run:
www.cat-lift.com

* Based on 5-year life cycle.

¹⁾ in most applications.

MORE PRODUCTIVITY

Performance At Its Best

The 2EPC7000-2EP11000 series raises the bar on performance. Ahead of the curve in design, this series features fully-enclosed AC motors, providing higher performance and greater uptime.

ENERGY EFFICIENT, 3-PHASE AC TECHNOLOGY

This lift truck's innovative three-phase AC motors are engineered for maximum efficiency and performance. Through advanced regenerative braking, the motors are designed to act as a generator during braking, effectively turning the truck's momentum into energy and feeding it back into the battery. This, combined with the truck's intelligent design and compact component layout, results in:

- **Longer run times** – up to two shifts on one battery charge in most applications.
- **Greater torque** – even at a lower speed, with no torque gaps and no speed loss.
- **High throughput efficiency** – even when changing travel directions.

DYNAMIC PERFORMANCE

Advanced AC technology also ensures responsive acceleration and braking, allowing for:

- Precise positioning
- Dynamic acceleration
- Controlled travel speed on ramps
- Less brake component wear for lower maintenance costs

RELIABLE MOTORS

Closed electric motors allow these lift trucks to operate in environments that previously only IC trucks could handle.

- **Fully-enclosed motor** – A motor with fewer parts means less maintenance needed. The motor's compact design and proximity to other components provides increased energy efficiency, helping you get more out of each shift.
- **Ingress protected** – The truck's sealed systems provide better protection against dust, moisture and other debris to take on your toughest applications.
 - IP54-rated motors
 - IP56-rated connectors

LESS MAINTENANCE, EASY TO SERVICE

With extended service intervals and sealed components, these lift trucks provide greater uptime to keep your business moving.

- 500-hour extended service intervals
- Display-based maintenance reminders
- Easy access to service components



Compact design for energy efficiency



Efficient AC controller



MOVE MORE - FASTER

High-Performance Motors Option

For demanding applications where throughput is a top priority, this option provides increased travel, lift and lowering speeds and enhanced gradeability. Ask your local Cat lift truck dealer for more information.

MORE COMFORT AND CONTROL

Precision Handling, Smooth Ride

Built to take on demanding applications, this series delivers the comfort and control operators need. Premium ergonomics, excellent visibility and a smooth controlled ride all come together to help your operators achieve maximum productivity – all day, every day.

TOTAL CONTROL

Your operators will enjoy this lift truck's high degree of control and its quiet, comfortable ride.



- **Fingertip hydraulic controls** – integrated directly into the armrest, these controls deliver low-effort handling and precise control. For added convenience, the travel direction switch and horn are incorporated into the armrest for one-touch access during operation. An optional unitized joystick control is also available, offering full control of the lift truck in the palm of your hand.

- **Five programmable performance modes** – allow customization of travel and other operational settings to be tailored to your specific application.



- **Soft ride, (rubber) solid pneumatic tires** – offer a smooth, quiet ride while eliminating the risk of flat tires as a result of sharp floor debris.

- **Advanced Curve Control technology** – automatically reduces travel speed when turning, providing added security for the operator and the load.

- **Operator presence detection system** – automatically disengages the hydraulic controls and sets the parking brake when the operator is not in the proper operating position.

OPTIMIZED VISIBILITY: FROM FRONT TO BACK

The lift truck's smart design provides excellent all-around visibility and clear sight lines to the surrounding job site. The open layout of the overhead guard, and slim profile of the mast, offer excellent forward visibility when driving and lifting, while programmable forward work lights provide ample lighting for various work environments.



2-way adjustable armrest

A one-touch adjustment puts control at your fingertips.

2-way adjustable steering column

More leg room with lower steering effort.

3-way adjustable full-suspension seat

Comfort for operators of any size.

Anti-cinch seat belt

Effortless reverse travel.

What Makes A Comfortable Ride

Operators can work long shifts comfortably in a wide range of applications due to the lift truck's ergonomic design. Less fatigue means more productivity throughout the shift.

Fully-floating operator cabin

Reduces shock and vibration for a smooth ride.



Local service and support



Genuine OEM parts



Custom financing packages

MORE CONFIDENCE





Factory warranty for added protection



Local Support You Can Count On

A Cat lift truck purchase connects you to a variety of material handling solutions, including world-class service and support from your local, trusted dealer. With factory-trained service technicians, a diverse parts inventory and a broad selection of service options, your local dealer can help you lower costs, enhance productivity and more efficiently manage your business.

FINANCING MADE SIMPLE

Financing your next Cat lift truck is easy with our wide range of flexible leasing and purchasing options. Whether you want to finance or lease, your local Cat lift truck dealer can help customize a package for your business.

WHEN EVERY PART COUNTS

When buying from your local Cat lift truck dealer, you can rest assured that your genuine OEM parts are manufactured to meet original equipment criteria. Additionally, all Cat lift truck OEM parts come with a six-month, unlimited-hours warranty.

When speed is critical, our Parts Fast Or Parts Free Guarantee* ensures next-business-day delivery of all Cat lift trucks parts, or they're free, including freight. If your part doesn't come in by the next business day, we pay for it.

STANDING BEHIND OUR PRODUCTS

We deliver peace of mind by helping your lift trucks stay on the job. Every new Cat lift truck is covered by a 1-year / 2,000-hours warranty that includes parts and labor, as well as components and systems. With our standard 2-year / 4,000-hours extended powertrain warranty, you'll have the confidence that only comes from owning a Cat lift truck.

* At dealer's location.

† Programs may be subject to change without notice and may vary by region. Please ask your local Cat lift truck dealer for complete terms and conditions.

Specifications

| Characteristics | | | | 2EPC7000 | | 2EPC8000 | | 2EP8000 | |
|-----------------|---|------|------|--------------------|-----------------|--------------------|-----------------|--------------------|-----------------|
| 1 | Capacity at rated load center | lb | kg | 7,000 | 3,500 | 8,000 | 4,000 | 8,000 | 4,000 |
| 2 | Rated load center | in | mm | 24 | 500 | 24 | 500 | 24 | 500 |
| 3 | Power – diesel, gasoline, LP gas, electric | | | electric | | electric | | electric | |
| 4 | Tire type – cushion, pneumatic | | | pneumatic | | pneumatic | | pneumatic | |
| 5 | Wheels, number front / rear (x=driven) | | | 2x / 2 | | 2x / 2 | | 2x / 2 | |
| Dimensions | | | | 2EPC7000 | | 2EPC8000 | | 2EP8000 | |
| 6 | Maximum fork height (see tables) | in | mm | 122 | 3,100 | 118 | 3,000 | 118 | 3,000 |
| 7 | Extended mast height | in | mm | 166 | 4,220 | 166 | 4,220 | 166 | 4,220 |
| 8 | Fork free lift height (see tables) | in | mm | 6 | 150 | 6 | 150 | 6 | 150 |
| 9 | Fork dimensions – length x width x thickness | in | mm | 45 X 5 X 1.8 | 1150 X 125 X 45 | 45 X 5 X 2 | 1150 X 125 X 50 | 45 X 5 X 2 | 1150 X 125 X 50 |
| 10 | Fork spacing – out-to-out minimum / maximum | in | mm | 16.4 / 44.3 | 415 / 1,125 | 16.4 / 44.3 | 415 / 1,125 | 16.4 / 44.3 | 415 / 1,125 |
| 11 | Fork carriage (to ISO 2328, class / type A, B) | | | 3A | | 3A | | 3A | |
| 12 | Mast tilt forward / backward | deg | | 6° / 8° | | 6° / 8° | | 6° / 8° | |
| 13 | Overall length (incl. 45.25 in. forks) | in | mm | 151.4 | 3,844 | 150.3 | 3,818 | 156.0 | 3,962 |
| 14 | Length to fork face (includes fork thickness) | in | mm | 105.4 | 2,677 | 105.0 | 2,668 | 110.7 | 2,812 |
| 15 | Overall width | in | mm | 52.8 | 1,340 | 52.8 | 1,340 | 52.8 | 1,340 |
| 16 | Lowered mast height | in | mm | 90.6 | 2,300 | 88.6 | 2,250 | 88.6 | 2,250 |
| 17 | Ground to seat index point | in | mm | 40.9 | 1,040 | 40.9 | 1,040 | 40.9 | 1,040 |
| 18 | Overhead guard height | in | mm | 93.1 | 2,365 | 93.1 | 2,365 | 93.1 | 2,365 |
| 19 | Tow coupling height | in | mm | 15.6 | 396 | 15.6 | 396 | 15.6 | 396 |
| 20 | Minimum outside turning radius | in | mm | 89.9 | 2,284 | 89.9 | 2,284 | 96.5 | 2,450 |
| 21 | Load distance, axle to fork face (load moment constant) | in | mm | 20.5 | 519 | 20.1 | 510 | 20.1 | 510 |
| 22 | Minimum aisle – 90° stack – zero clearance without load | in | mm | 110.4 | 2,803 | 110.0 | 2,794 | 116.5 | 2,960 |
| Performance | | | | 2EPC7000 | | 2EPC8000 | | 2EP8000 | |
| 23 | Travel speed, loaded / no load (standard mode) | mph | km/h | 9.3 / 10 | 15 / 16 | 8.7 / 10 | 14 / 16 | 8.7 / 10 | 14 / 16 |
| 24 | Travel speed, loaded no load (high-performance option) | mph | km/h | 10.6 / 11.1 | 17 / 18 | 9.3 / 10.6 | 15 / 17 | 9.3 / 10.6 | 15 / 17 |
| 25 | Lift speed, loaded / no load (standard mode) | fpm | m/s | 74.8 / 98.4 | 0.38 / 0.50 | 61.0 / 84.6 | 0.31 / 0.43 | 61.0 / 84.6 | 0.31 / 0.43 |
| 26 | Lift speed, loaded / no load (high-performance option) | fpm | m/s | 84.6 / 108.2 | 0.43 / 0.55 | 68.9 / 98.4 | 0.35 / 0.50 | 68.9 / 98.4 | 0.35 / 0.50 |
| 27 | Lowering speed, loaded / no load (standard mode) | fpm | m/s | 110.2 / 110.2 | 0.56 / 0.56 | 106.3 / 90.6 | 0.54 / 0.46 | 106.3 / 90.6 | 0.54 / 0.46 |
| 28 | Lowering speed, loaded / no load (high-performance option) | fpm | m/s | 110.2 / 110.2 | 0.56 / 0.56 | 108.3 / 98.4 | 0.55 / 0.50 | 108.3 / 98.4 | 0.55 / 0.50 |
| 29 | Gradeability, loaded at 1 mph (1.6 kmh) (standard mode) | % | | 10.2 | | 9.3 | | 9.3 | |
| 30 | Gradeability, loaded at 1 mph (1.6 kmh) (high-performance option) | % | | 11.5 | | 10.8 | | 10.8 | |
| 31 | Gradeability, maximum (no load) (standard mode) | % | | 24.0 | | 22.3 | | 22.3 | |
| 32 | Gradeability, maximum (no load) (high-performance option) | % | | 27.8 | | 26.1 | | 26.1 | |
| Weight | | | | 2EPC7000 | | 2EPC8000 | | 2EP8000 | |
| 33 | Chassis with minimum weight battery, no load | lb | kg | 12,645 | 5,736 | 14,623 | 6,633 | 14,533 | 6,592 |
| 34 | Axle loading with rated load, front / rear ²⁾ | lb | kg | 18,136 / 2,226 | 8,226 / 1,010 | 21,265 / 2,177 | 9,646 / 987 | 21,224 / 2,128 | 9,627 / 965 |
| 35 | Axle loading with no load, front / rear ²⁾ | lb | kg | 6,420 / 6,225 | 2,912 / 2,824 | 7,725 / 6,899 | 3,504 / 3,129 | 8,037 / 6,495 | 3,646 / 2,946 |
| Chassis | | | | 2EPC7000 | | 2EPC8000 | | 2EP8000 | |
| 36 | Tire size, front | in | | 250 - 15 | | 250 - 15 | | 250 - 15 | |
| 37 | Tire size, rear | in | | 21 x 8 - 9 | | 21 x 8 - 9 | | 21 x 8 - 9 | |
| 38 | Wheelbase | in | mm | 73.1 | 1,856 | 73.1 | 1,856 | 78.7 | 2,000 |
| 39 | Track width, front / rear (center of tires) | in | mm | 43.9 / 37.4 | 1,115 / 950 | 43.9 / 37.4 | 1,115 / 950 | 43.9 / 37.4 | 1,115 / 950 |
| 40 | Ground clearance at lowest point of mast | in | mm | 5.6 | 143 | 5.4 | 136 | 5.4 | 136 |
| 41 | Ground clearance at center of wheelbase | in | mm | 5.9 | 150 | 5.9 | 150 | 5.9 | 150 |
| 42 | Brakes – service | type | | wet disc hydraulic | | wet disc hydraulic | | wet disc hydraulic | |
| 43 | Brakes – parking | type | | hydraulic | | hydraulic | | hydraulic | |
| Electrical | | | | 2EPC7000 | | 2EPC8000 | | 2EP8000 | |
| 44 | Battery physical size, maximum ¹⁾ | in | mm | 33.66x40.47x30.87 | 855x1028x784 | 33.66x40.47x30.87 | 855x1028x784 | 39.33x40.47x30.87 | 999x1028x784 |
| 45 | Battery weight, minimum / maximum | lb | kg | 3,902 / 4,436 | 1,770 / 2,012 | 3,902 / 4,436 | 1,770 / 2,012 | 4,562 / 5,186 | 2,069 / 2,352 |
| 46 | Drive motor capacity (60 min. rating) (standard mode) | HP | kW | 19 | 14.5 | 19 | 14.5 | 19 | 14.5 |
| 47 | Drive motor capacity (60 min. rating) (high-performance option) | HP | kW | 24 | 18 | 24 | 18 | 24 | 18 |
| 48 | Lift output (15% rating) (standard mode) | HP | kW | 27 | 20 | 27 | 20 | 27 | 20 |
| 49 | Lift output (15% rating) (high-performance option) | HP | kW | 32 | 24 | 32 | 24 | 32 | 24 |
| 50 | Truck voltage | Volt | | 80 Volts | | 80 Volts | | 80 Volts | |
| 51 | Controls – drive / hydraulic | type | | AC / AC | | AC / AC | | AC / AC | |
| 52 | Hydraulic pressure for attachments | PSI | Mpa | 2900 | 20 | 2900 | 20 | 2900 | 20 |
| 53 | Hydraulic flow rate for attachments | gpm | lpm | 79 | 30 | 79 | 30 | 79 | 30 |

1) Dimensions represent maximum battery size, not compartment size.

2) Battery weight 4107 lbs/1863 kg on models 2EPC7000, 2EP8000, 2EPC9000; battery weight 4801 lbs/2178 kg on 2E11000.

| 2EP8500 | | 2EPC9000 | | 2EP9000 | | 2EP10000 | | 2EP11000 | |
|--------------------|-----------------|--------------------|-----------------|--------------------|-----------------|--------------------|-----------------|--------------------|-----------------|
| 8,500 | 4,000 | 9,000 | 4,500 | 9,000 | 4,500 | 10,000 | 5,000 | 11,000 | 5,000 |
| 24 | 600 | 24 | 500 | 24 | 500 | 24 | 500 | 24 | 600 |
| electric | | electric | | electric | | electric | | electric | |
| pneumatic | | pneumatic | | pneumatic | | pneumatic | | pneumatic | |
| 2x / 2 | | 2x / 2 | | 2x / 2 | | 2x / 2 | | 2x / 2 | |
| 2EP8500 | | 2EPC9000 | | 2EP9000 | | 2EP10000 | | 2EP11000 | |
| 118 | 3,000 | 118 | 3,000 | 118 | 3,000 | 118 | 3,000 | 118 | 3,000 |
| 166 | 4,220 | 166 | 4,220 | 166 | 4,220 | 166 | 4,220 | 166 | 4,220 |
| 6 | 150 | 6 | 150 | 6 | 150 | 6 | 150 | 6 | 150 |
| 45 X 6 X 2 | 1150 X 150 X 50 | 45 X 6 X 2 | 1150 X 150 X 50 | 45 X 6 X 2 | 1150 X 150 X 50 | 45 X 6 X 2 | 1150 X 150 X 50 | 45 X 6 X 2.4 | 1150 X 150 X 60 |
| 16.5 / 44.5 | 420 / 1,130 | 16.5 / 44.5 | 420 / 1,130 | 16.5 / 44.5 | 420 / 1,130 | 16.5 / 44.5 | 420 / 1,130 | 16.5 / 44.5 | 420 / 1,130 |
| 3A | | 3A | | 3A | | 3A | | 4A | |
| 6° / 8° | | 6° / 8° | | 6° / 8° | | 6° / 8° | | 6° / 8° | |
| 161.5 | 4,102 | 150.3 | 3,818 | 144.1 | 3,660 | 156.0 | 3,962 | 161.5 | 4,102 |
| 116.2 | 2,952 | 105.0 | 2,668 | 110.7 | 2,812 | 110.7 | 2,812 | 116.2 | 2,952 |
| 57.1 | 1,450 | 57.1 | 1,450 | 57.1 | 1,450 | 57.1 | 1,450 | 57.1 | 1,450 |
| 88.0 | 2,236 | 88.0 | 2,236 | 88.0 | 2,236 | 88.0 | 2,236 | 88.0 | 2,236 |
| 40.9 | 1,040 | 40.9 | 1,040 | 40.9 | 1,040 | 40.9 | 1,040 | 40.9 | 1,040 |
| 92.5 | 2,350 | 92.5 | 2,350 | 92.5 | 2,350 | 92.5 | 2,350 | 92.5 | 2,350 |
| 15.6 | 396 | 15.6 | 396 | 15.6 | 396 | 15.6 | 396 | 15.6 | 396 |
| 103.8 | 2,637 | 89.9 | 2,284 | 96.5 | 2,450 | 96.5 | 2,450 | 103.8 | 2,637 |
| 20.1 | 510 | 20.1 | 510 | 20.1 | 510 | 20.1 | 510 | 20.1 | 510 |
| 123.9 | 3,147 | 110.0 | 2,794 | 116.5 | 2,960 | 116.5 | 2,960 | 123.9 | 3,147 |
| 2EP8500 | | 2EPC9000 | | 2EP9000 | | 2EP10000 | | 2EP11000 | |
| 8.7 / 9.6 | 14 / 15.5 | 8.7 / 9.6 | 14 / 15.5 | 8.7 / 9.6 | 14 / 15.5 | 8.7 / 9.3 | 14 / 15 | 8.4 / 9 | 13.5 / 14.5 |
| 9.3 / 10.3 | 15 / 16.5 | 9.3 / 10.3 | 15 / 16.5 | 9.3 / 10.3 | 15 / 16.5 | 9.3 / 10 | 15 / 16 | 9 / 9.6 | 9.6 / 15.5 |
| 59.1 / 80.7 | 0.30 / 0.41 | 59.1 / 80.7 | 0.30 / 0.41 | 59.1 / 80.7 | 0.30 / 0.41 | 55.1 / 80.7 | 0.28 / 0.41 | 53.1 / 78.7 | 0.27 / 0.40 |
| 65.0 / 88.6 | 0.33 / 0.45 | 65.0 / 88.6 | 0.33 / 0.45 | 65.0 / 88.6 | 0.33 / 0.45 | 65.0 / 88.6 | 0.33 / 0.45 | 61.0 / 88.6 | 0.31 / 0.45 |
| 102.4 / 92.5 | 0.52 / 0.47 | 102.4 / 92.5 | 0.52 / 0.47 | 102.4 / 92.5 | 0.52 / 0.47 | 102.4 / 92.5 | 0.52 / 0.47 | 100.4 / 98.4 | 0.51 / 0.50 |
| 108.3 / 98.4 | 0.55 / 0.50 | 108.3 / 98.4 | 0.55 / 0.50 | 108.3 / 98.4 | 0.55 / 0.50 | 108.3 / 98.4 | 0.55 / 0.50 | 108.3 / 98.4 | 0.55 / 0.50 |
| 8.1 | | 8.1 | | 8.1 | | 7.5 | | 7.1 | |
| 9.4 | | 9.4 | | 9.4 | | 8.8 | | 8.4 | |
| 20.4 | | 20.4 | | 20.4 | | 20 | | 18.9 | |
| 23.4 | | 23.9 | | 23.9 | | 23.4 | | 22.2 | |
| 2EP8500 | | 2EPC9000 | | 2EP9000 | | 2EP10000 | | 2EP11000 | |
| 15,580 | 7,067 | 15,637 | 7,093 | 15,547 | 7,052 | 16,402 | 7,440 | 17,476 | 7,927 |
| 21,886 / 2,522 | 9,927 / 1,144 | 23,200 / 2,358 | 10,524 / 1,069 | 23,039 / 2,429 | 10,450 / 1,102 | 24,656 / 2,747 | 11,184 / 1,246 | 25,528 / 2,971 | 11,579 / 1,348 |
| 8,448 / 7,132 | 3,832 / 3,235 | 7,962 / 7,675 | 3,612 / 3,481 | 8,200 / 7,349 | 3,720 / 3,333 | 8,196 / 8,207 | 3,718 / 3,722 | 8,551 / 8,925 | 3,879 / 4,048 |
| 2EP8500 | | 2EPC9000 | | 2EP9000 | | 2EP10000 | | 2EP11000 | |
| 28 x 12.5 - 15 | | 28 x 12.5 - 15 | | 28 x 12.5 - 15 | | 28 x 12.5 - 15 | | 28 x 12.5 - 15 | |
| 23 x 10 - 12 | | 21 x 8 - 9 | | 21 x 8 - 9 | | 21 x 8 - 9 | | 23 x 10 - 12 | |
| 81.9 | 2,080 | 73.1 | 1,856 | 78.7 | 2,000 | 78.7 | 2,000 | 81.9 | 2,080 |
| 43.9 / 47.2 | 1,115 / 1,200 | 43.9 / 37.4 | 1,115 / 950 | 43.9 / 37.4 | 1,115 / 950 | 43.9 / 37.4 | 1,115 / 950 | 43.9 / 47.2 | 1,115 / 1,200 |
| 4.8 | 122 | 4.8 | 122 | 4.8 | 122 | 4.8 | 122 | 4.8 | 122 |
| 5.9 | 150 | 5.9 | 150 | 5.9 | 150 | 5.9 | 150 | 5.9 | 150 |
| wet disc hydraulic | | wet disc hydraulic | | wet disc hydraulic | | wet disc hydraulic | | wet disc hydraulic | |
| hydraulic | | hydraulic | | hydraulic | | hydraulic | | hydraulic | |
| 2EP8500 | | 2EPC9000 | | 2EP9000 | | 2EP10000 | | 2EP11000 | |
| 39.33x40.47x30.87 | 999x1028x784 | 33.66x40.47x30.87 | 855x1028x784 | 39.33x40.47x30.87 | 999x1028x784 | 39.33x40.47x30.87 | 999x1028x784 | 39.33x40.47x30.87 | 999x1028x784 |
| 4,562 / 5,186 | 2,069 / 2,352 | 3,902 / 4,436 | 1,770 / 2,012 | 4,562 / 5,186 | 2,069 / 2,352 | 4,562 / 5,186 | 2,069 / 2,352 | 4,562 / 5,186 | 2,069 / 2,352 |
| 19 | 14 | 19 | 14.5 | 19 | 14 | 19 | 14 | 19 | 14 |
| 24 | 18 | 24 | 18 | 24 | 18 | 24 | 18 | 24 | 18 |
| 27 | 20 | 27 | 20 | 27 | 20 | 27 | 20 | 27 | 20 |
| 32 | 24 | 32 | 24 | 32 | 24 | 32 | 24 | 32 | 24 |
| 80 Volts | | 80 Volts | | 80 Volts | | 80 Volts | | 80 Volts | |
| AC / AC | | AC / AC | | AC / AC | | AC / AC | | AC / AC | |
| 2900 | 20 | 2900 | 20 | 2900 | 20 | 2900 | 20 | 2900 | 20 |
| 7.9 | 30 | 7.9 | 30 | 7.9 | 30 | 7.9 | 30 | 7.9 | 30 |

2EPC7000-2EP11000

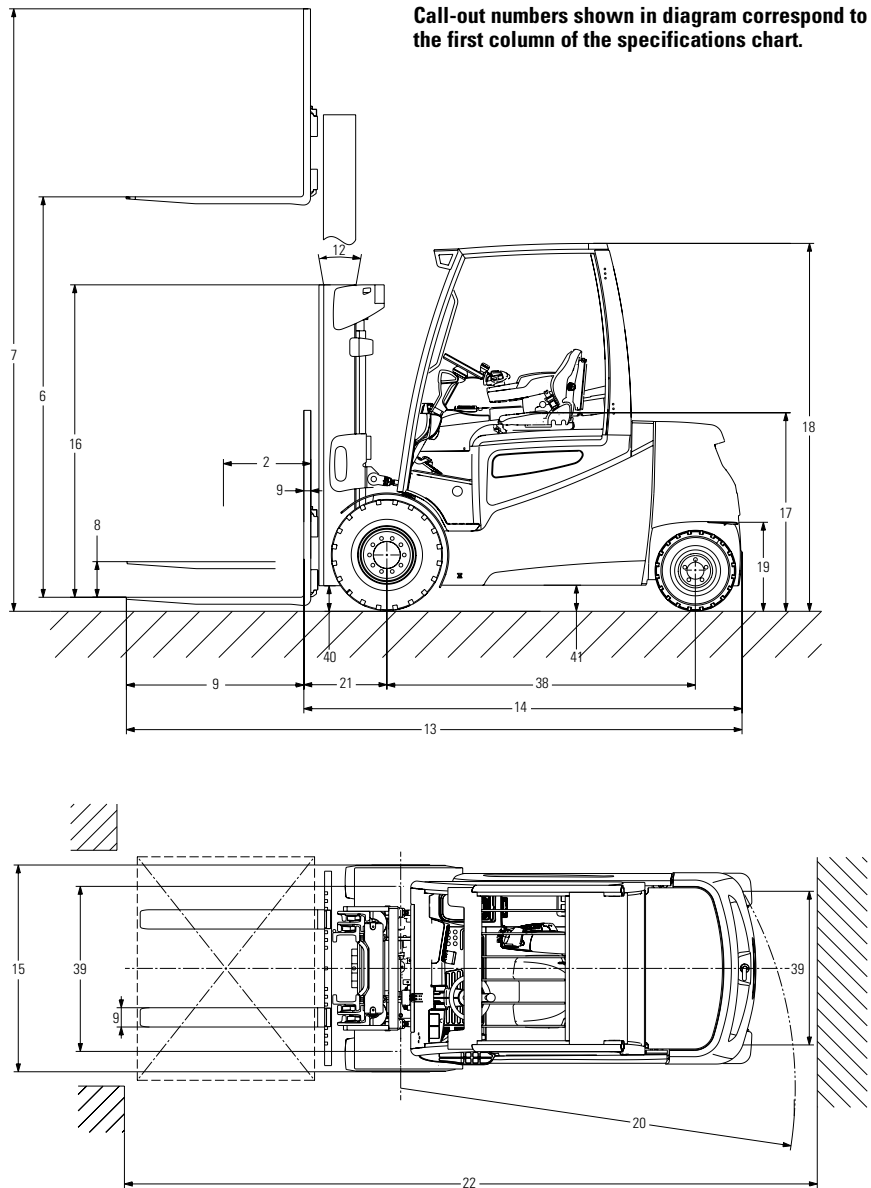

NOTE: These specifications assume the use of drive axles, tires and tilt angles specified. Any modification to specifications, or any other combination of specifications made after the shipment of the truck, requires prior written approval from Mitsubishi Caterpillar Forklift America Inc. (MCFA). (See ANSI/ITSDF B56.1.) Also be advised that overall operating visibility may be affected by the mast configuration and mast options of your forklift truck. Therefore, you may need to add ancillary [auxiliary] devices or modify your operating practices. Consult your dealer for further information.

Safety Standards

These trucks meet American National Standards Institute / Industrial Truck Standards Development Foundation, ANSI/ITSDF B56.1. Users should be aware of, and adhere to, applicable codes and regulations regarding operator training, use, operation and maintenance of powered industrial trucks, including:

- ANSI/ITSDF B56.1.
- NFPA 505, fire safety standard for powered industrial trucks – type designations, areas of use, maintenance, and operation.
- Occupational Safety and Health Administration (OSHA) regulations that may apply.

Specifications, equipment, technical data, photos and illustrations based on information at time of printing and subject to change without notice. Some products may be shown with optional equipment.

MORE OPTIONS



Comfort (closed) cabin



Access authorization



Joystick unitized control

Enhance Your Operation

Additional options are also available to further customize the lift truck for your business.



Electric heater



Rear charging port



Advanced ergo seat

Comfort (closed) cabin

Helps protect operators from adverse weather conditions. This cabin has additional options to further boost productivity in even the harshest environments.

Access authorization

Allows operator access via keypad with assigned user codes.

Advanced ergo seat

This 5-way adjustable seat can improve operator comfort when driving over long distances.

Hydraulic accumulator

Provides additional cushioning when carrying heavy loads.

Dual solid pneumatic tires

Better distributes floor loading weight on unpaved surfaces when carrying a load.



15° swivel seat



Light packages



Hydraulic accumulator

Cold storage or Tropics modification

Equips the lift truck with special fluids and conditioning for optimal performance in cold or humid storage environments.

Travel speed reduction

Limits the top travel speed based on workplace preferences.



Dual solid pneumatic tires



Cold storage / Tropics modification



Raised operator cab (for special applications)

*Ask your local dealer for a complete list of options.



Your Cat lift truck dealer can provide additional options and features to specialize your lift truck for your unique application. Operator training and custom financing programs are also available to help find the right fit for your business.

Helping move businesses forward – that's how we're built.

BUILT FOR IT.™

1-800-CAT-LIFT | www.cat-lift.com

© 2015 MCFA. All Rights Reserved. CAT, CATERPILLAR, BUILT FOR IT, their respective logos, "CaterpillarYellow," the "Power Edge" trade dress as well as corporate and product identity used herein, are trademarks of Caterpillar and may not be used without permission. All registered trademarks are the property of their respective owners. Some products may be shown with optional equipment.

CECM0028-02

09/15

CAT® Lift
Trucks